



Operator's Handbook

Suspended Arm

SAR15 Z 5

Code: 010690/Z/5

SAR15 XZ 85

Code: 010690/XZ/85

SAR15 XYZ 855

Code: 010690/XYZ/855

KOLVER S.r.l.
VIA MARCO CORNER, 19/21
36016 THIENE (VI) ITALIA
TEL +39 0445 371068
www.kolver.it



KOLVER S.r.l.

VIA MARCO CORNER, 19/21

36016 THIENE (VI) ITALIA

Declare that the suspended arm here described:

SAR15 Z 5

SAR15 XZ 85

SAR15 XYZ 855

Suspended Arm

Is in conformity with the following standards and other normative documents:
2006/42/CE, EN12100

It is also in conformity with RoHS II normative.

Name: Giovanni Colasante

Position: General Manager

Person authorized to compile the technical file in Kolver

Thiene, January 1st 2019

Giovanni Colasante

Z



XZ



XYZ

The new Suspended Torque Arms are the ideal solution to increase productivity. They can be easily installed on most work stations to help the operator handle the screwdriver in total safety and stability. With minimized reaction force you will also improve finished product quality because there is no movement of the tool and all torque is absorbed in the joint. They also improve the comfort of the operator and the productivity clearing the work area and maximizing use of the space.

Three models available, depending on the motion of the axis:

SAR15 Z -> Z Axis

SAR15 XZ 85 -> XZ Axis

SAR15 XYZ 855 -> XYZ Axis

	SAR15 Z 5	SAR15 XZ 85	SAR15 XYZ 855
Verticale lenght "Z" (mm)	364	364	885
Horizontal lenght "X" (mm)	/	692	692
Lateral lenght "Y" (mm)	/	/	376
Torque MAX (Nm)	15	15	15

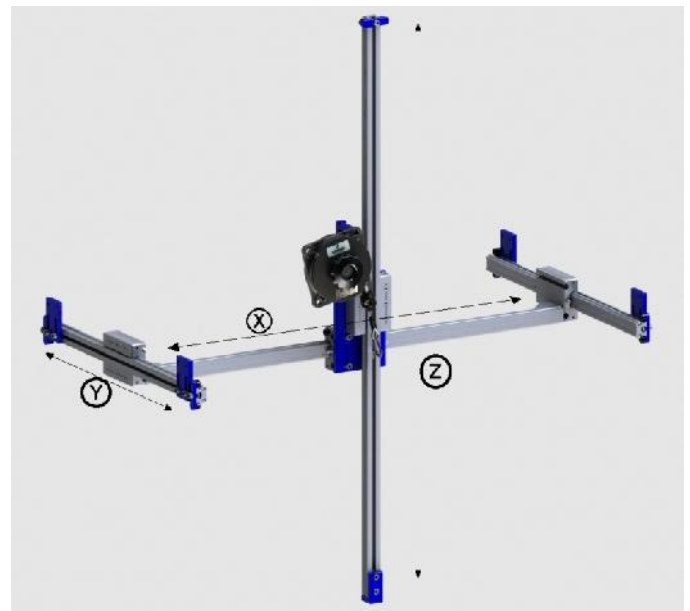

Dimensional drawings

Z Arm

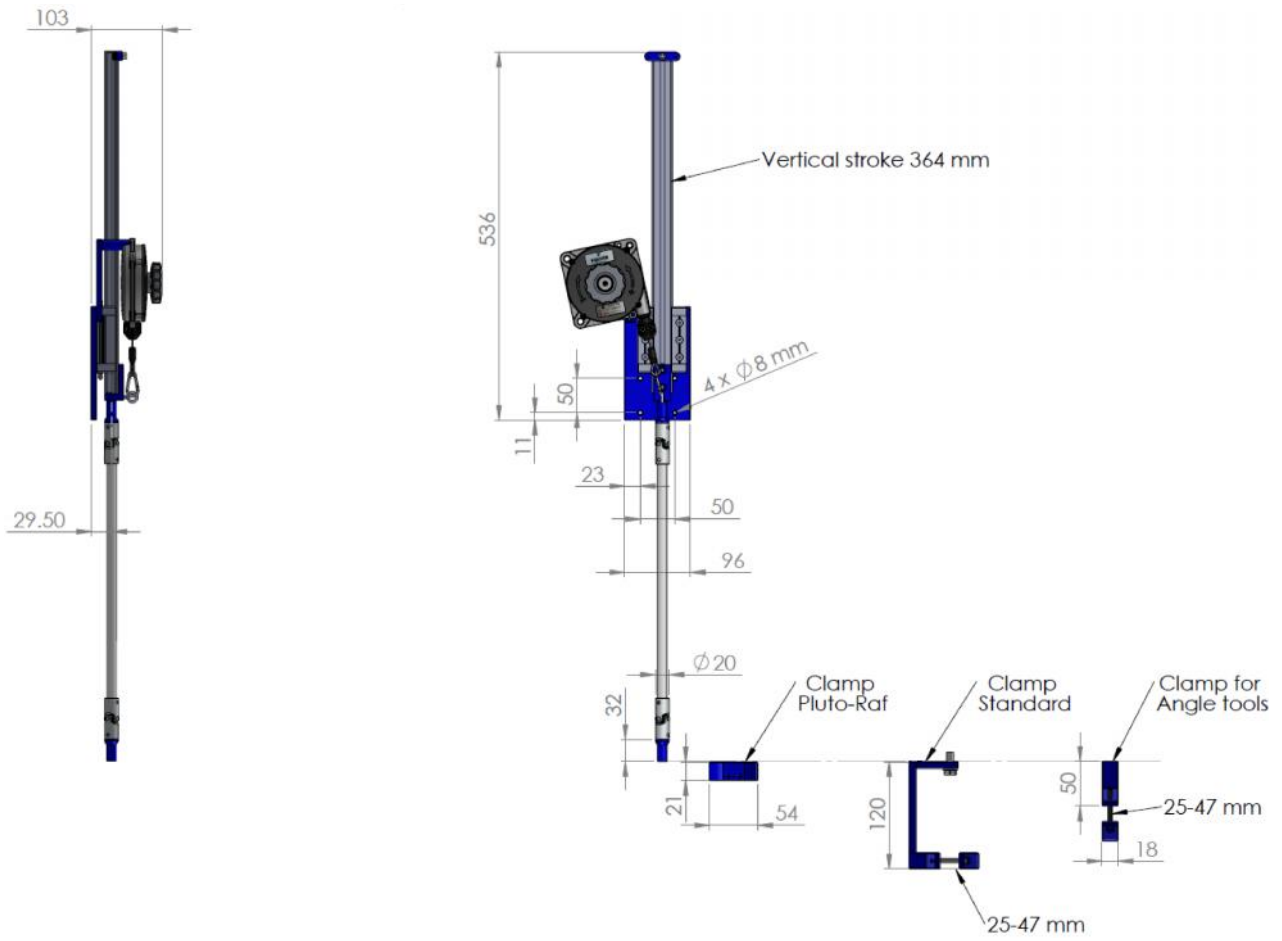

XZ Arm

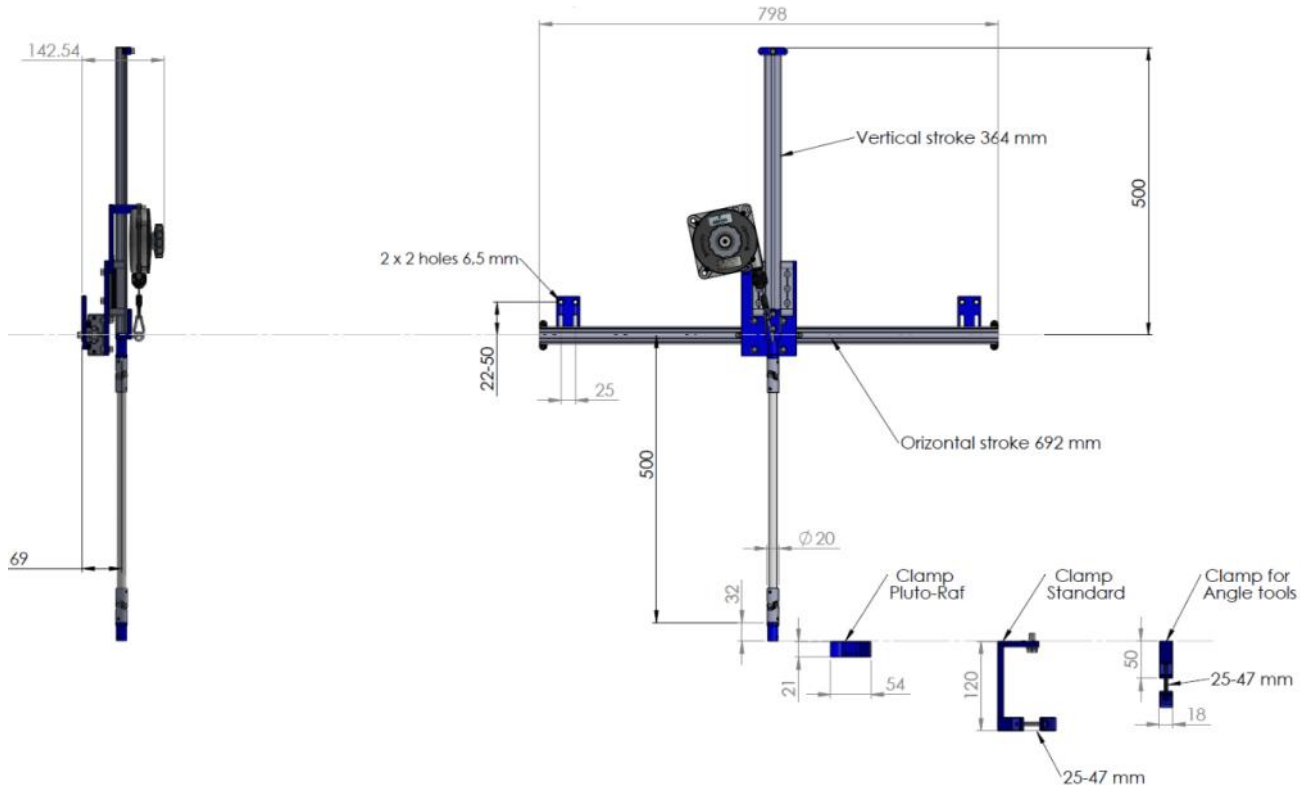

XYZ Arm

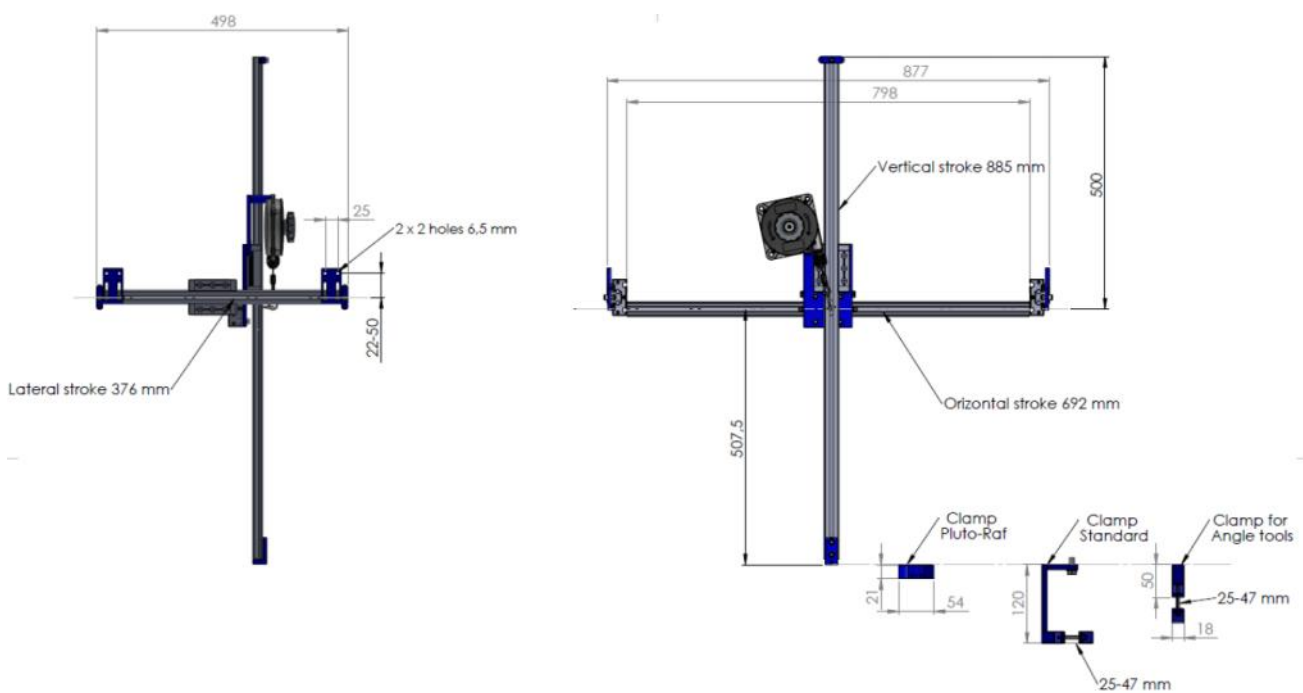

Setting

1) To adjust the carriages

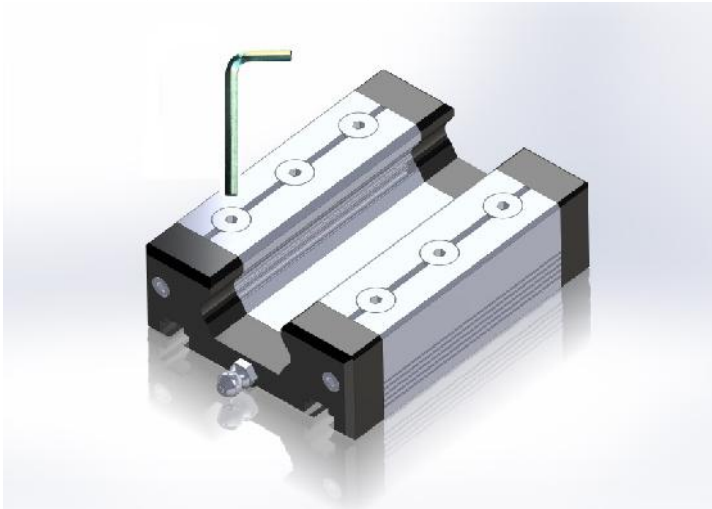

First, if necessary, adjust the sliding of the carriages on the linear bar by acting on the screws on the carriage itself. Turning clockwise, the rigidity and the precision of the arm will increase. Kolver provides pre-calibrated screws at 0.55 Nm.

2) To remove the limit switch

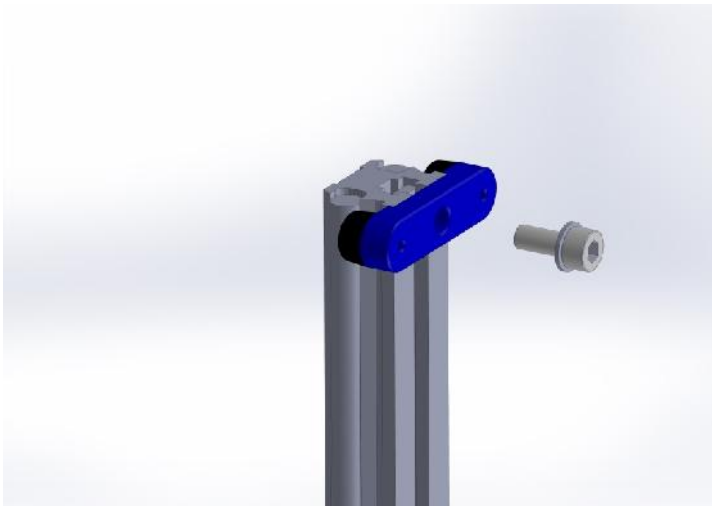

The switch limits can be moved and/or removed by loosening the screw.

Inside the guide it runs the corresponding square nut on which you will have to tighten the screw to fix the limit switch.

3) To fix the balancer

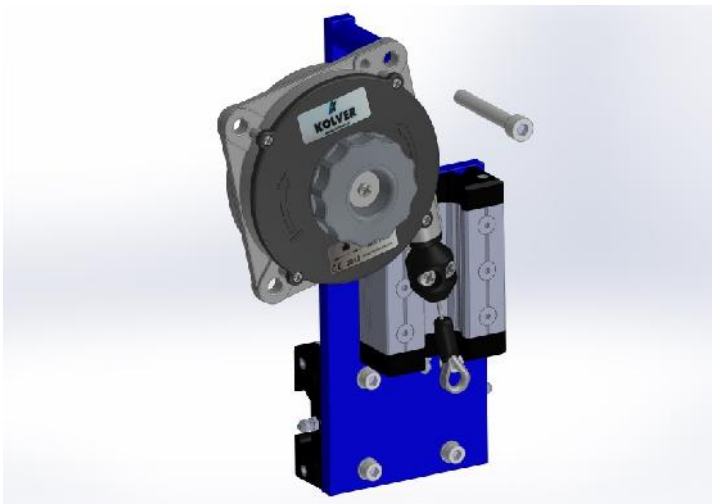

Loosen the supplied M8 screw and fix the balancer.

4) To insert the horizontal bar (only on XZ and XYZ models)

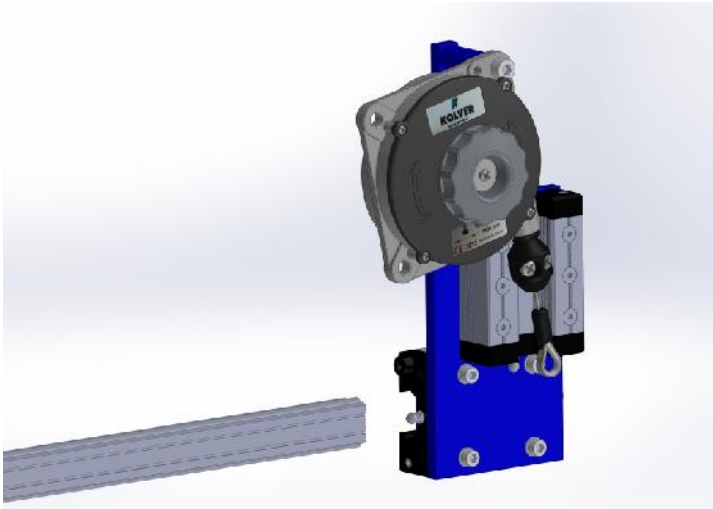

After removing the limit switch, insert the horizontal bar on the appropriate guide of the carriage.

5) To fix the horizontal bar of XZ model

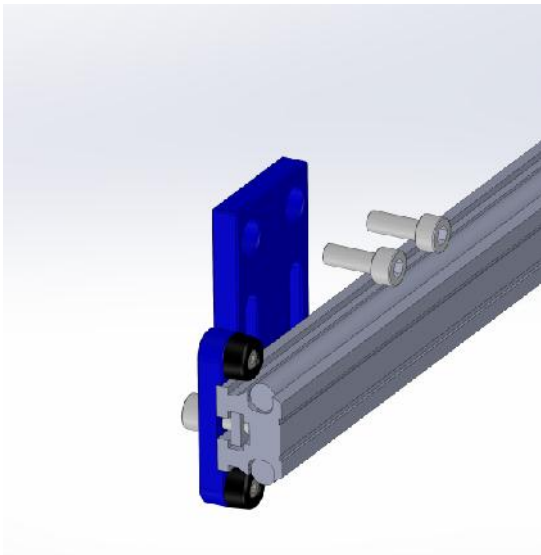

Place the supports to fix the system on both sides of the horizontal bar.

6) To adjust the tilt of the horizontal bar

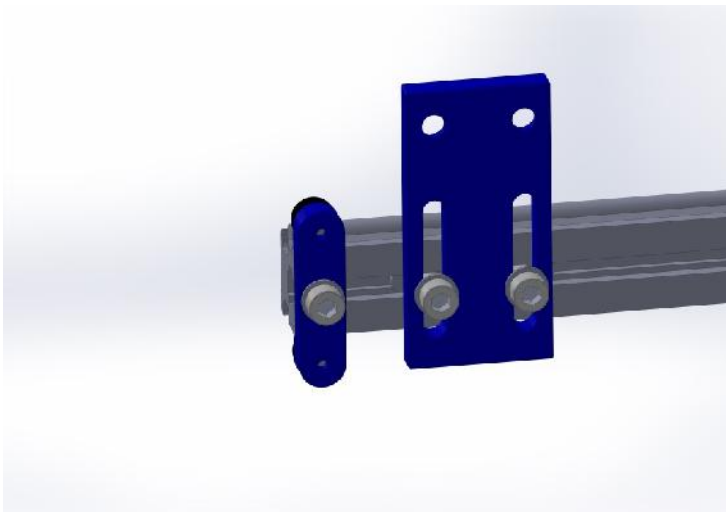

Adjust the screws on the rails in order to give the desired tilt to the bar and, once released the screwdriver, the carriage can slide to the default position.

7) To fix lateral bars of XYZ model

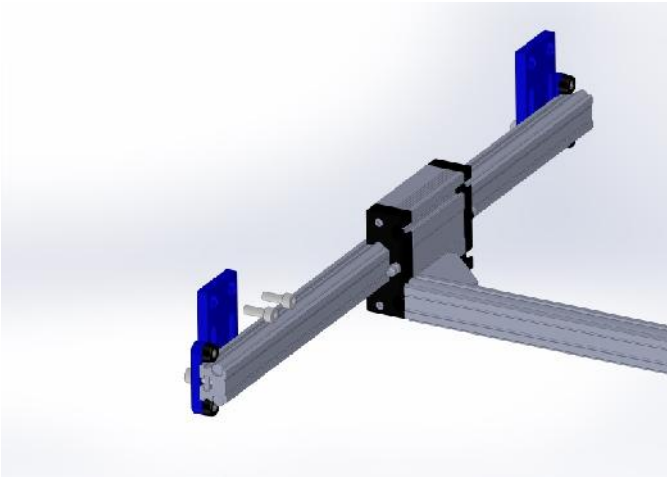

On XYZ model, fix the lateral bars with relative screws at 877 mm from each other to allow the assembly of the horizontal bar.

This can even be done after assembling the whole arm.

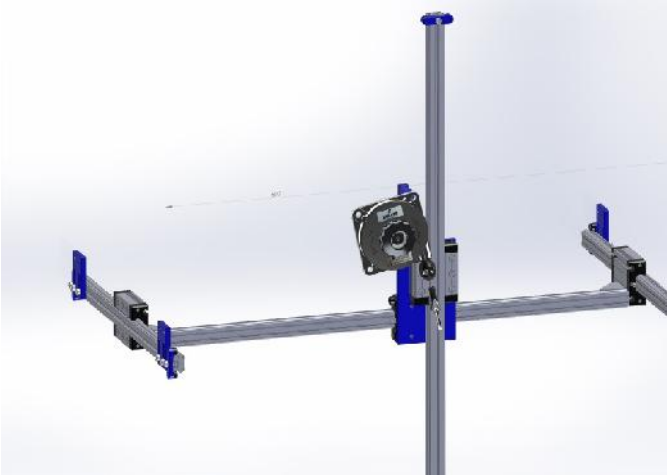

8) To fix horizontal bar on XYZ model

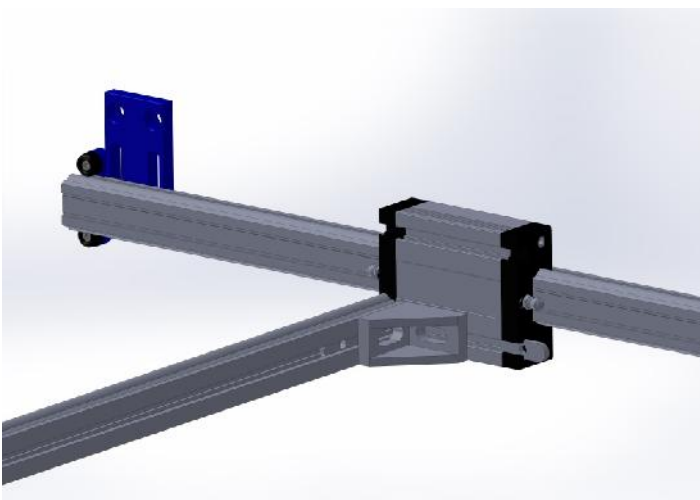

Place the horizontal bar as shown in figure holding the bracket parallel to the carriage, insert the threaded nuts and fix both sides.

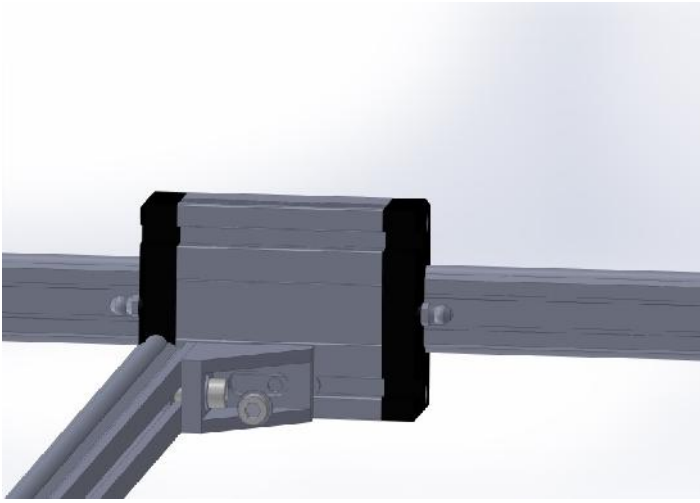

9) To fix the vertical bar (all the SAR models)

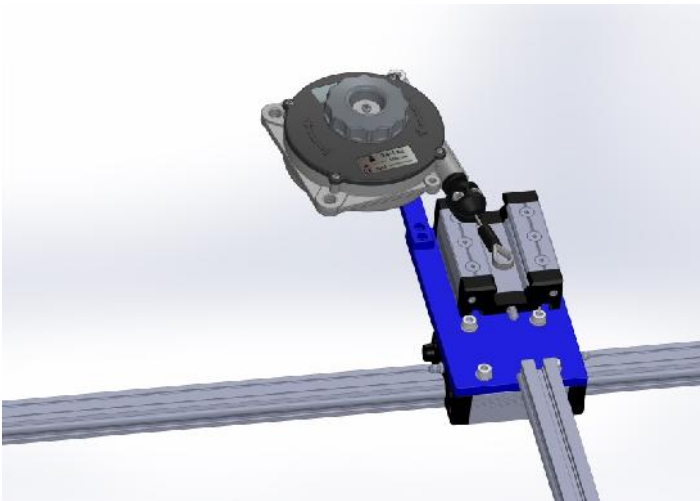

Remove the limit switch (see point 2) and insert vertical bar (see point 4). Reassemble the limit switch.

10) To fix the balancer cable on SAR Z and XZ models

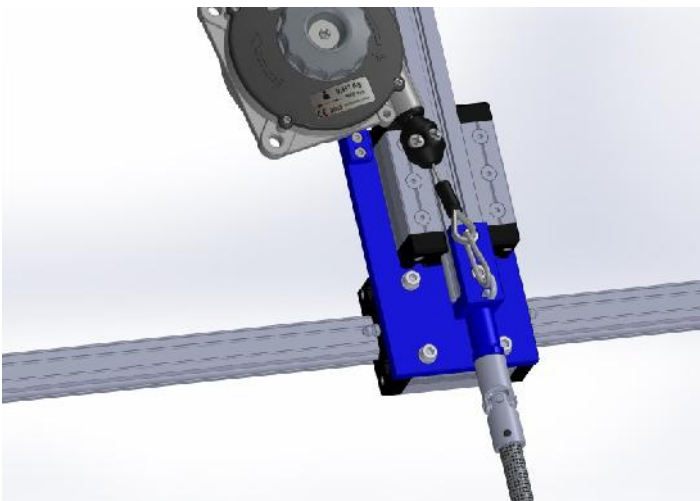

Bring the loop to the balancer and clip the carabiner. Depending on the weight of the tool used, turn the knob of the balancer to find the right setting.

11) To fix the balancer cable on SAR XYZ model

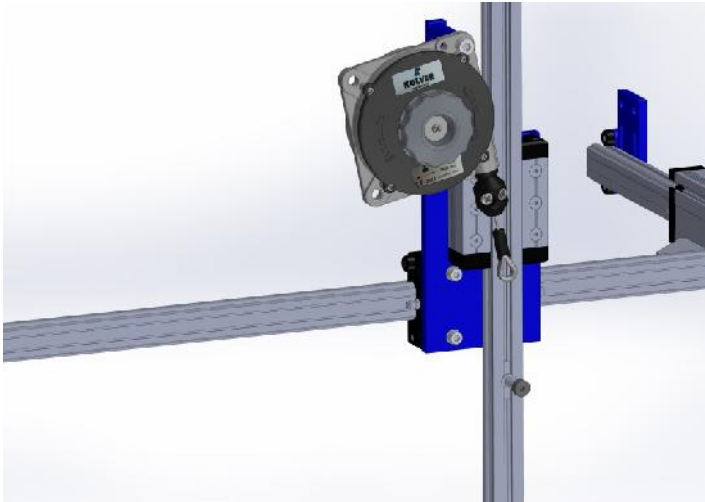

Loosen the screw, insert it in the loop of the balancer and screw it into the nut inside the rail.

Fix the screw in the desired position, adjusting the retaining ring in the cable of the balancer.

Depending on the weight of the tool used, turn the knob of the balancer to find the right setting.

12) To fix the carbon bar on SAR XZ model

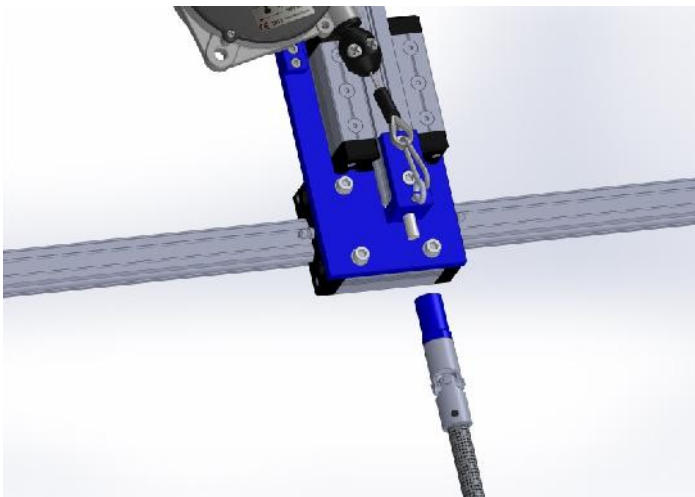

Screw the rod bush of the carbon bar on the threaded pin and secure it with a 18mm wrench.

Tighten the two M4 nut, being careful not to damage the thread of the pin.

If necessary, you can use the thread lock to prevent the unscrewing of both nuts and bush.

Accessories

PLUTO/RAF Clamp - Code 010695

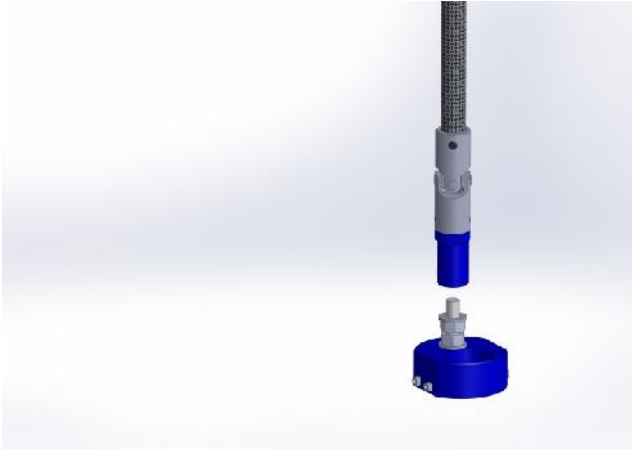

Screw the clamp in the aluminum bush for at least 5 mm, find the desired position and tighten nut + washer to lock the rotation.

If necessary, you can use the thread lock to prevent the unscrewing of this clamp.

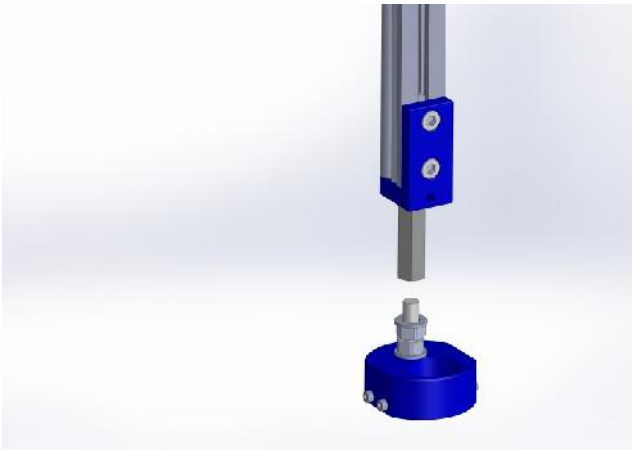

To fix the handle RAF / PLUTO, loosen the screws on the side of the support.

Remove the hook of the screwdriver.

Fit the tool and tighten the two screws on the hole of the hook.

The other two screws will be only placed in the housing to prevent any slack.

If necessary, you can use the thread lock to prevent the unscrewing of this clamp.



Clamp for pistol/angle screwdriver - Code 010695/P

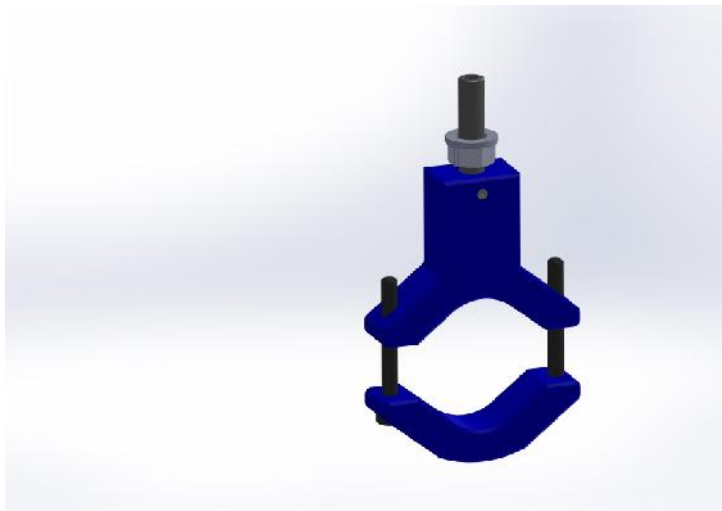

To secure the support of carbon bar, screw the threaded socket and lock the rotation with the nut.

To secure the support of XYZ model, first remove the M4 nuts then the M8 nut and screw it in the threaded pin this of the vertical bar. Then block the rotation with M4 nuts taking care not to damage the thread, then fix the locknut.

If necessary, you can use the thread lock to prevent the unscrewing of this clamp.

Universal clamp - Code 010695/UNI

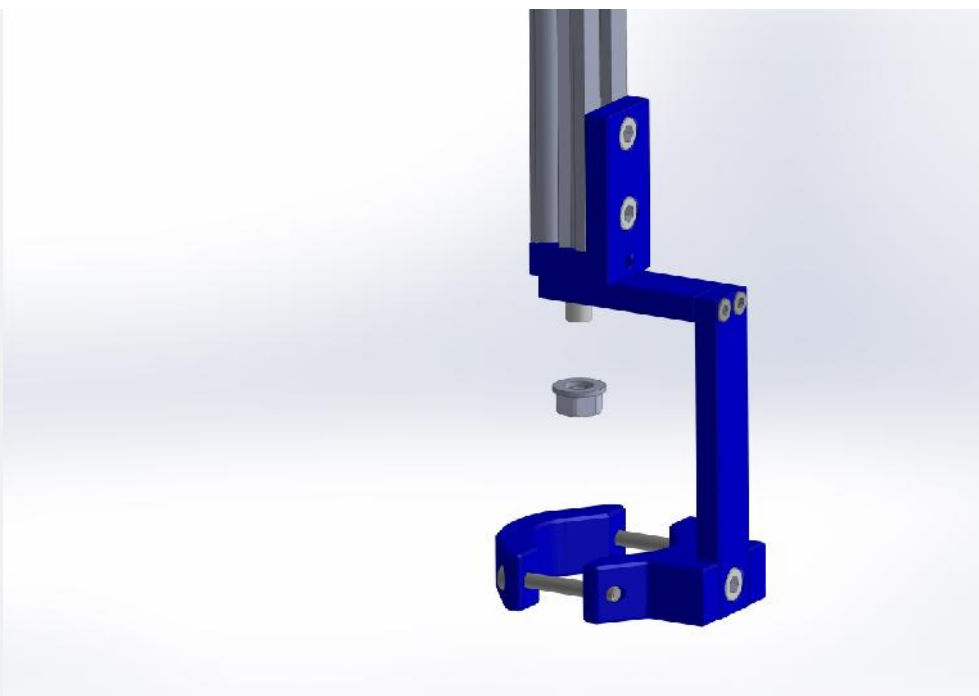

To secure the universal clamp on the carbon bar, tighten the screw M8 x 20 on the bush bushing and fix the M4 nut to prevent unscrewing.

To secure the support of XYZ model, screw the M8 nut + washer on the threaded pin of the vertical bar.

GUARANTEE

- 1) This KOLVER product is guaranteed against defective workmanship or materials, for a maximum period of 12 months following the date of purchase from KOLVER, provided that its usage is limited to single shift operation throughout that period. If the usage rate exceeds of single shift operation, the guarantee period shall be reduced on a prorata basis.
- 2) If, during the guaranteed period, the product appears to be defective in workmanship or materials, it should be returned to KOLVER or its distributors, transport prepaid, together with a short description of the alleged defect. KOLVER shall, at its sole discretion, arrange to repair or replace free of charge such items.
- 3) This guarantee does not cover repair or replacement required as a consequence of products which have been abused, misused or modified, or which have been repaired using not original KOLVER spare parts or by not authorized service personnel.
- 4) KOLVER accepts no claim for labor or other expenditure made upon defective products.
- 5) Any direct, incidental or consequential damages whatsoever arising from any defect are expressly excluded.
- 6) This guarantee replaces all other guarantees, or conditions, expressed or implied, regarding the quality, the marketability or the fitness for any particular purpose.
- 7) No one, whether an agent, servant or employee of KOLVER, is authorized to add to or modify the terms of this limited guarantee in any way. However it's possible to extend the warranty with an extra cost. Further information at kolver@kolver.it.